

BOILER & CONDENSER TUBE SHIELDS



KANAWHA
MANUFACTURING COMPANY

CHARLESTON, WEST VIRGINIA

Tube Shields-Outside Bend and Side Bend Types

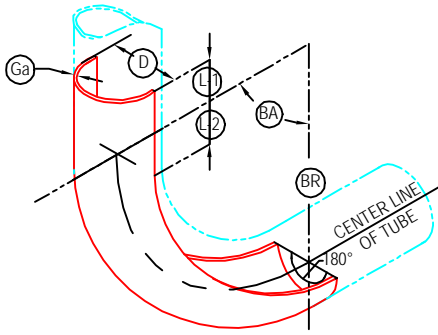

"O B" TYPE SHIELD
(Outside of Bend)

- (D) - Shield I.D. (Same as Tube O.D.)
- (L-1) - Length, Straight Section, One End
- (L-2) - Length, Straight Section, Other End
- (BA) - Tube Bend ARC
- (BR) - Tube Bend Radius
- (Ga) - Material Thickness

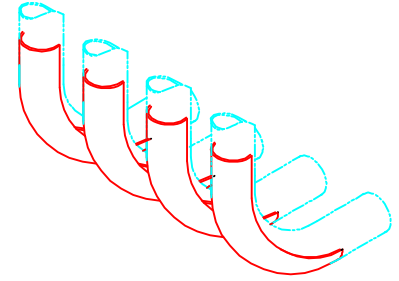

PROTECTION for
Curved Boiler Tubes

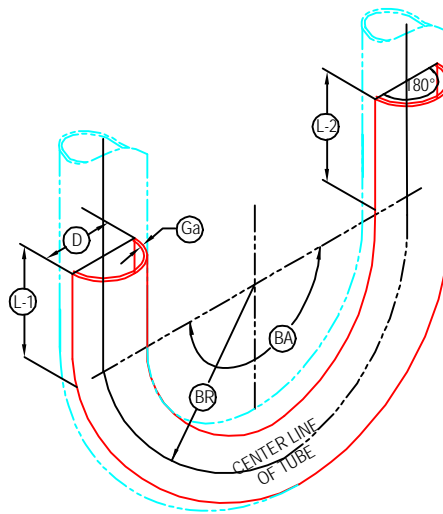

"S B" TYPE SHIELD
(side of Bend)

- (D) - Shield I.D. (Same as Tube O.D.)
- (L-1) - Length, Straight Section, One End
- (L-2) - Length, Straight Section, Other End
- (BA) - Tube Bend ARC
- (BR) - Tube Bend Radius
- (Ga) - Material Thickness

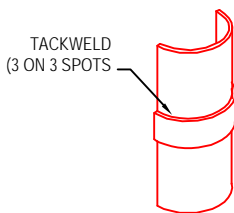

"SNAP-ON" CLIP
Used As Cover
Over Expansion Joint

- (D) - Clip I.D. (Same as Tube O.D.)
- (Ga) - Material Thickness

(1-A) - Clip ID Same as OD of Shield

Clip used as Shield Retainer

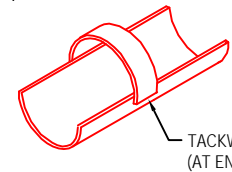
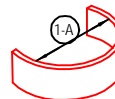

TACKWELD
(AT ENDS)

"SNAP-ON" TYPE CLIP

When Ordering SHIELDS and CLIPS* (or requesting quotation) please specify:

1-Type (or types) of Shield required; viz., "Snap on", "IB", "OB" or "SB"

2-Outside diameter of tubes to be protected.- (D)

3-Type of Stainless Steel desired; viz., 304, 310, 316 or other.

4-Material thickness required.- (Ga)

5-Number of each size Shield required.**

PLUS: For "Snap-On" Shields,

6-The length of each Shield.- (L)

For Curved Types

6- The degrees of Bend Arc.- (BA) the Radius of the
Tube Bend.- (BR) and, the length of straight section
each end.- (L-1) and (L-2)

*-Clips are Usually Ordered as so many per Shield; however, they can be supplied as Separate items. Sizes, Type of Stainless Steel and Material thickness should be specified as is done for Shields.

** -Quantity discounts are available

Tube Shields-Straight and inside Bend Types

"SNAP-ON" TYPE SHIELD

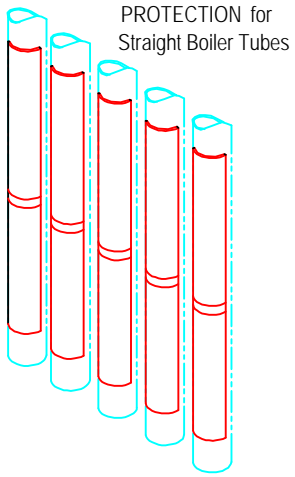

- (D) - Shield I.D. (Same as Tube O.D.)
- (L) - Length
- (Ga) - Material Thickness

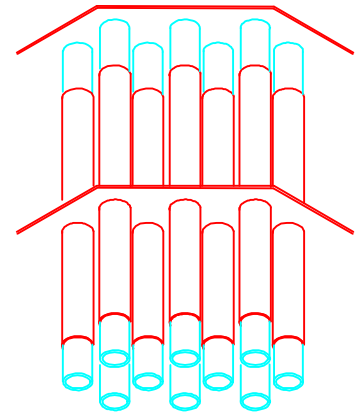
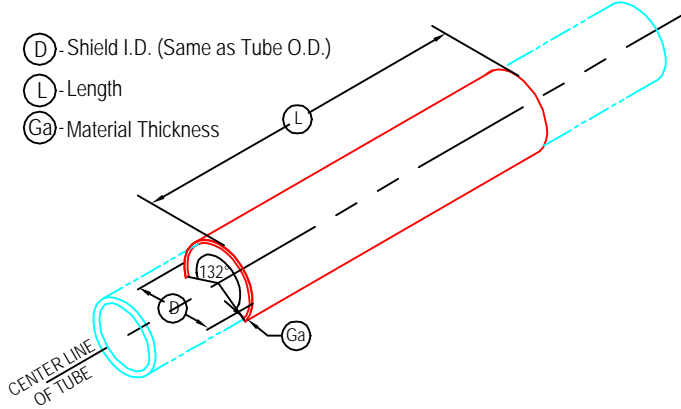

PROTECTION for Condenser Tubes

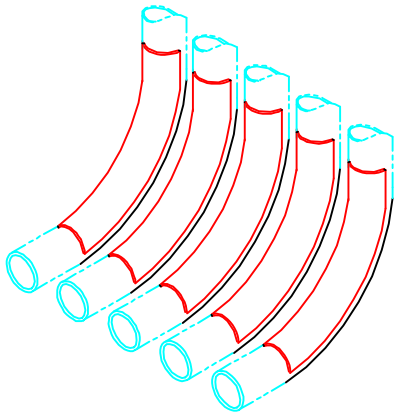

PROTECTION for Curved Boiler Tubes

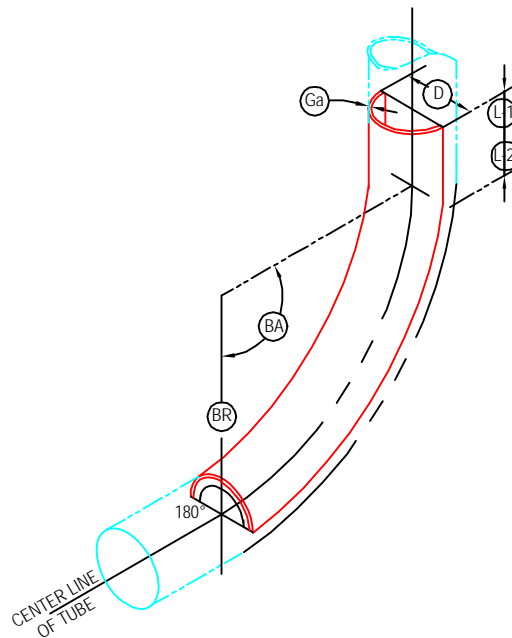

- (D) - Shield I.D. (Same as Tube O.D.)
- (L-1) - Length, Straight Section, One End
- (L-2) - Length, Straight Section, Other End
- (BA) - Tube Bend ARC
- (BR) - Tube Bend Radius
- (Ga) - Material Thickness

"I B" TYPE SHIELD

(Inside of Bend)

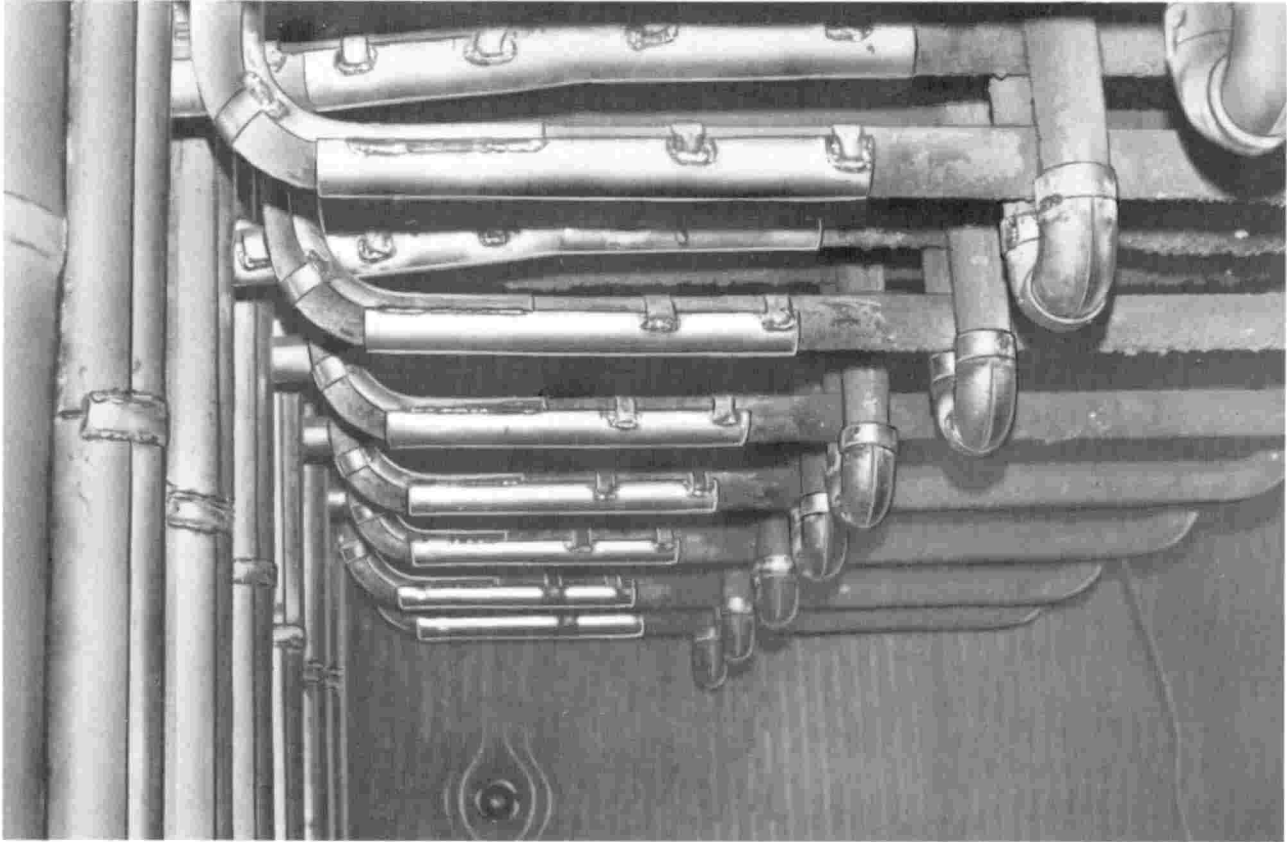

KANAWHA

Products for the Power Industry

REPLACEMENT PARTS

Vane wheel conversions, conversion parts for MPS-89 and EL-70 pulverizers, 863, 843 and 523 bowl mill conversions, expansion joints, seal skirts, boiler castings, etc.

STAINLESS STEEL ITEMS

Tube shields, nozzle tips, bin and chute liners, ash hopper repair parts, corrugated seal skirts, fan blades, scroll liners, clinker grinder housings.

OTHER FABRICATED, MACHINED and ENGINEERED ITEMS

Coal handling facilities, bins, feeders, rapid loading systems, dampers, fan blades and scrolls.

QUALITY PRODUCTS, ON-TIME DELIVERY

KANAWHA
MANUFACTURING COMPANY

**P.O. Box 1786 • Plant and Office, 1520 Dixie Street
Charleston, West Virginia 25326
Phone (304) 342-6127
Fax (304) 343-4113**